

SPC

PERFORMANCE®

Instruction Sheet - Infiniti/Nissan Rear Kit

Check out the **INSTALLATION VIDEO** at: <http://spc-tv.com>



This part should only be installed by personnel who have the necessary skill, training and tools to do the job correctly and safely. Incorrect installation can result in personal injury, vehicle damage and / or loss of vehicle control.

Plan Ahead - Read All Instructions **BEFORE** installing part.

Always check for loose or worn parts, tire pressure, and odd tire wear patterns.

1. Raise rear of vehicle and properly support by frame.
2. Remove rear tire and wheel assembly.
3. Remove lower camber link (this arm has a factory camber adjustment cam at inner end – **Figure 1**).
4. Ensure that SPC adjustable arm has equal thread showing on either side of turnbuckle. Install bushing end inboard using original bolts. Loosely install mounting hardware with cam bolt in neutral position.
5. Place a jack under coil spring seat to support lower control arm during pivot removal and reinstallation.
6. Remove factory toe cam and drop arm from frame by raising vehicle slightly or lowering jack under coil seat.

NOTE: Rear spring may need to be removed to allow inner pivot of arm to swing down due to frame pocket wrapping around arm.

CAUTION: Always use appropriate safety devices to support weight of vehicle while servicing any suspension component.

7. Use provided template or ut out template below and center on existing slot in vehicle. Mark area to elongate slots

on both sides.

8. Use #85130 Rotary File Set or equivalent to elongate slots. Check hole size by placing SPC bolt with cam into hole and rotating 360 degrees. If cam bolt cannot complete a full rotation, extend slot further.
9. If spring was removed, reinstall it prior to replacing control arm. Reinstall control arm by raising jack supporting arm and install bolt with a cam on either side. Loosely install lock nut.
10. Reinstall tire and wheel assembly and lower vehicle.
11. Adjust toe and camber using SPC toe cam and adjustable control arm. When adjustments are made, tighten fasteners to manufacturer's specification. Tighten adjustable arm lock nuts.
12. Complete vehicle alignment and road test vehicle.

NOTE: Maximum length of arm is reached when machined flat on threaded rod is visible at end of turnbuckle. **DO NOT** lengthen arm beyond this point.

Always check for proper clearance between suspension components and other components of the vehicle.

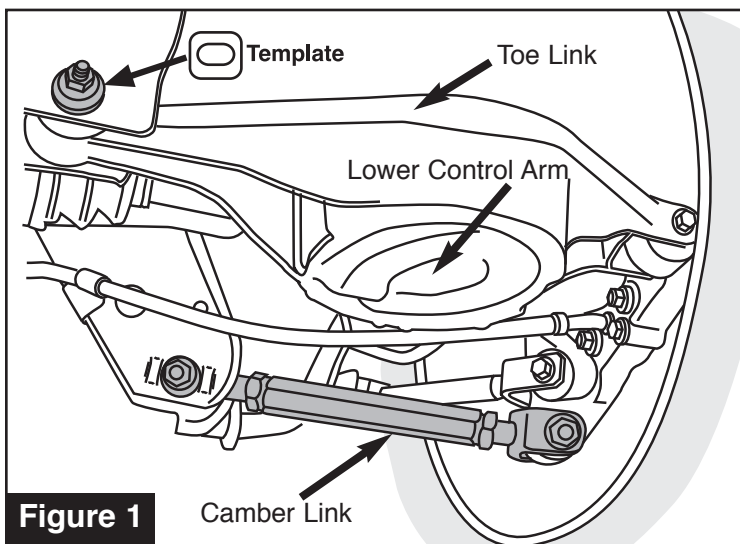
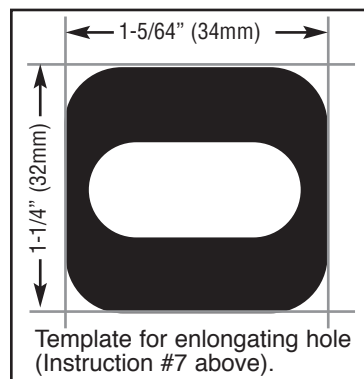

Figure 1



Specialty Products Company®

P.O. Box 923 • Longmont, CO 80502 • (303) 772-2103 • Fax: (303) 772-1918 • www.specprod.com • www.spcperformance.com • Email: info@specprod.com
Toll Free Technical Hot Line: 1-800-525-6505 ©2015 Niwot Corp. dba Specialty Products Co.® • Printed in U.S.A. • Form No. 98050 • Rev. 10/15 • ECN#1956