



INFINITI.

GENUINE PARTS

INSTALLATION INSTRUCTIONS

DESCRIPTION: REAR SPOILER KIT - CARBON FIBER

APPLICATION: INFINITI Q60

PART NUMBER: T99J1 5CH0B

KIT CONTENTS:

Item	Qty.	Part Description
A	1	Spoiler Assembly
B	4	M5 Nuts (w/ Blue Loctite)
C	2	Plastic Clips
D	4	Nut Spacers
E	1	Installation Instruction Replacement Template
F	1	Spoiler Hole Drill Template [Mylar] - Trunk Lid Outer
G	2	Access Hole Drill Templates [Paper] - Trunk Lid Inner

TOOLS REQUIRED:

- Clean shop rags
- Masking tape
- Drop cloth
- Vacuum
- Hammer
- Center punch
- Phillips screwdriver
- Awl
- Tape measure
- Variable speed drill
- Drill bits: 1/8" or 3mm, 9/32" or 7mm, 1/4" or 6mm
- Hole saw: 1 1/4" or 30mm
- Torque wrench
- Drill Stop
- Ratchet with extension
- 8mm deep socket
- Alcohol solution 90% or greater
- Deburring Tool
- Rust Preventative (P/N 999MP-9G001P)
- Microfiber cloth

PRE-INSTALLATION WARNINGS, CAUTIONS, CRITICAL STEPS, and NOTES:

- Dealer Installation Recommended. Instructions may refer to Service Manual.

⚠ WARNING

- Some plastic surfaces may become damaged by alcohol solution. Cover and protect taillight lenses. If alcohol does come into contact with the lens, immediately wash surface with water.
- Failure to clean mounting surface properly may cause tape to have poor adhesion to vehicle.
- If vehicle has been recently painted, allow paint to dry and age 24 hours before installing spoiler.
- Install spoiler when ambient temperature is above 15 °C (60 °F).
- Do not wash or expose vehicle to a wet environment for 24 hrs. after installing spoiler.
- Use proper pressure of 103kpa (15 lb/in) applied with a dry, soft, clean rag to adhere spoiler tape.

INSTALLATION PROCEDURE:

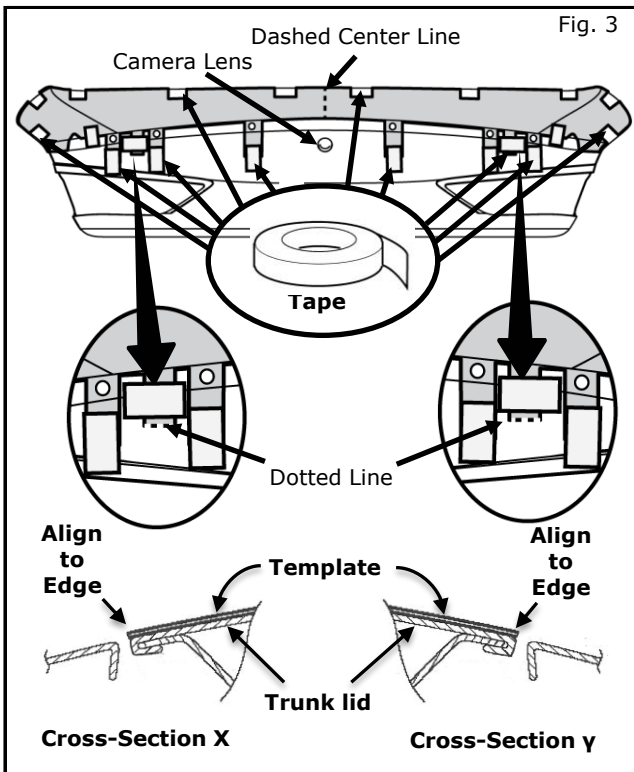
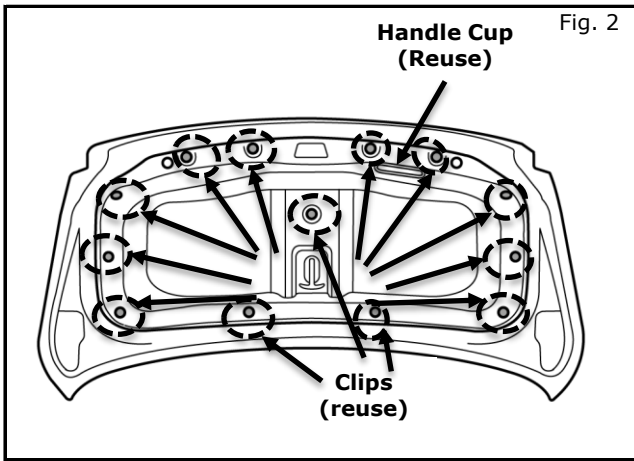
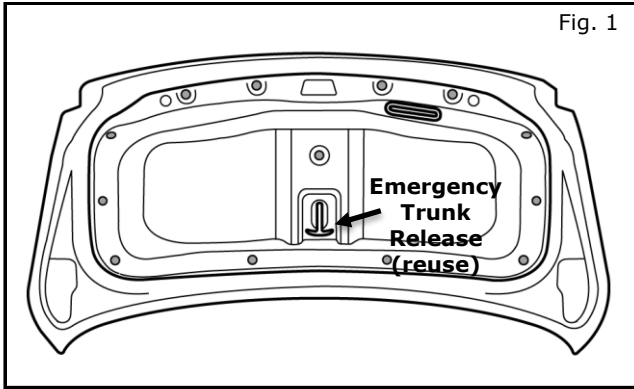

- 1) Apply parking brake.
- 2) Inner liner removal.
 - a) Open trunk lid.
 - b) Place drop cloth in trunk to cover and protect inside.
 - c) Gently pry emergency trunk release from decklid (Fig. 1).
 - d) Remove and retain (13) fasteners using flat blade screwdriver (Fig. 2).
 - e) Remove liner.

NOTE:
Handle cup comes out when liner is removed.

- 3) Close trunk lid.
- 4) Position outer drill template and drill holes.
 - a) Align drill template to edges of trunk lid.
 - b) Tape template to trunk lid at tape marks shown on template in sequential order. Leave dotted line visible along lower edge of tabs 11 and 17.

NOTE:
Ensure template is properly aligned by checking dashed center line with camera lens in center of decklid prior to marking hole centers.

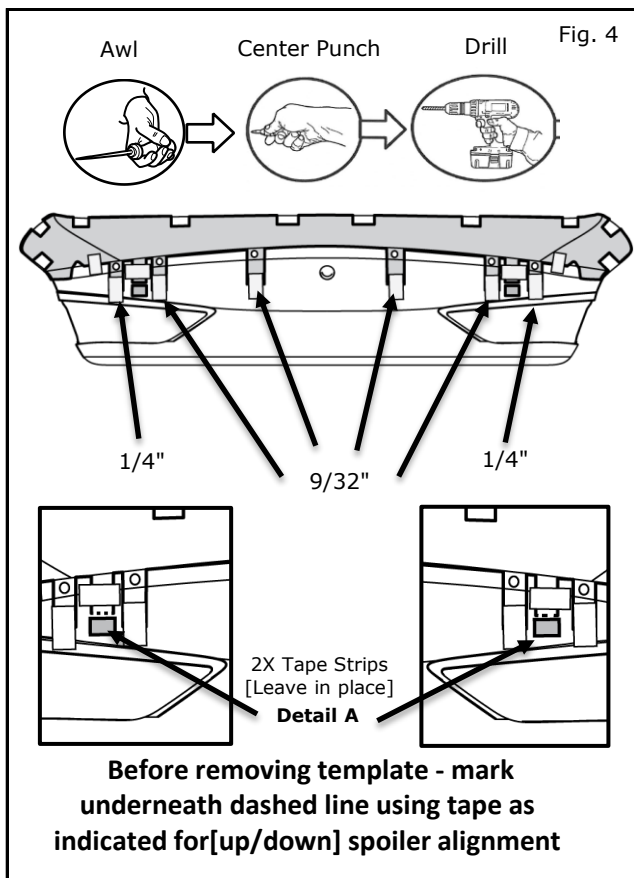

(Step 4 Continued).

- c) Mark trunk lid hole centers through crosshairs on template using an awl and then center punch (Fig. 4). Six (6) places total.
- d) Place tape strips on trunk lid (underneath dotted line of template tabs 11 and 17) to indicate position for up/down spoiler alignment. (Fig 4, Detail A).

NOTE:

- **Tape strip should be same width as dotted line.**
- **Leave tape strips in place until spoiler is secured to trunk lid.**

- e) Remove drill template from trunk lid.

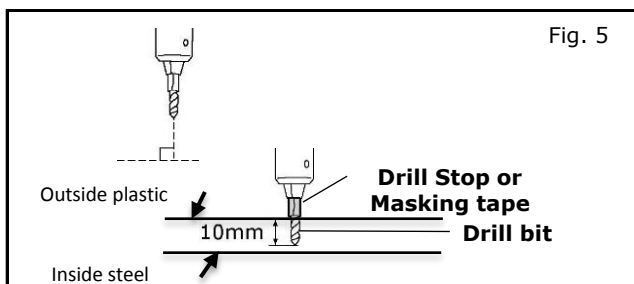

- g) To prevent drill tip from contacting inner trunk sheet metal, wrap masking tape around drill bits approximately 10mm from tip or use drill stop if available (Fig. 5).
- h) Being careful not to allow drill to contact inner sheet metal, drill 1/8" [3.0mm] pilot holes at six punch mark locations (Fig. 4).
- i) Drill holes to final sizes as shown (Fig. 4). Four center holes 9/32" [7.0mm] and two outer holes 1/4" [6.0mm].

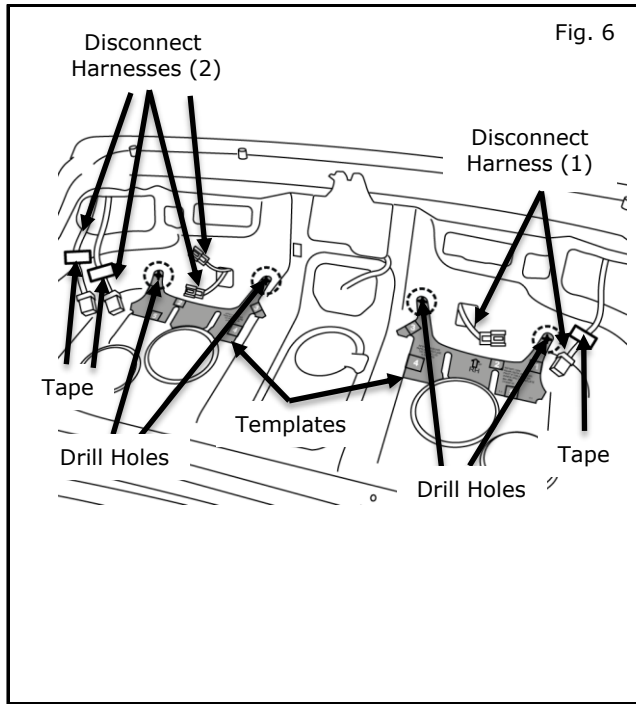

- 5) Locate and drill access holes (4).
 - a) Open trunk lid.
 - b) Disconnect wiring harnesses at (3) locations.
 - c) Tape harness connectors out of drill access path as shown (Fig. 6).
 - d) Position LH and RH templates (included in kit). Align templates to trunk lid inner as specified on template and tape in place.
 - e) Locate and punch mark center of four holes.
 - f) Remove templates.
 - g) Drill 3mm (1/8") pilot holes at each punch mark location (Fig. 6).
 - h) Using 30mm (1 1/4") hole saw, drill holes to final size.
 - i) Use deburring tool to clean sharp edges of holes and coat exposed metal edges with rust preventative.
 - j) Vacuum and remove all debris after drilling.

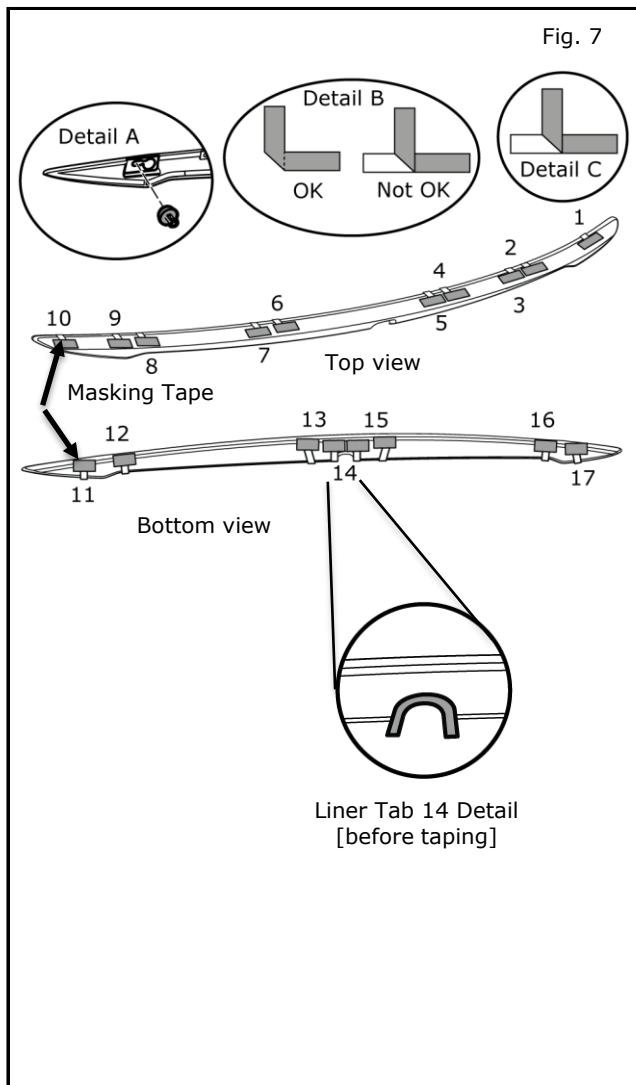

- 6) Attaching rear spoiler to trunk lid.
 - a) Close trunk lid.
 - b) Attach supplied plastic push clips in key hole slot at each end of spoiler as shown in "Detail A".
 - c) Surface of trunk lid must be cleaned with alcohol 90% solution or greater for proper tape adhesion. Let dry thoroughly.
 - d) Trunk temperature should be at least 60°F (15.5°C) for proper start-up adhesion of tape. Use hot air blower if temperature is below 60°F.
 - e) Carefully peel back liner tabs and tape to spoiler using masking tape as shown. Ensure liner tabs are folded as shown in "Detail B" (Fig. 7).
 - f) When folding back tape liners, expose 1" of adhesive tape at locations 4 and 6 only to hold spoiler in place after positioning correctly as shown in "Detail C" (Fig. 7).
 - g) Adjust 4 sliding studs and 2 sliding clips into holes. Confirm even spacing LH to RH at outboard edges of spoiler and make sure that the spoiler is spaced evenly around rear camera lens.

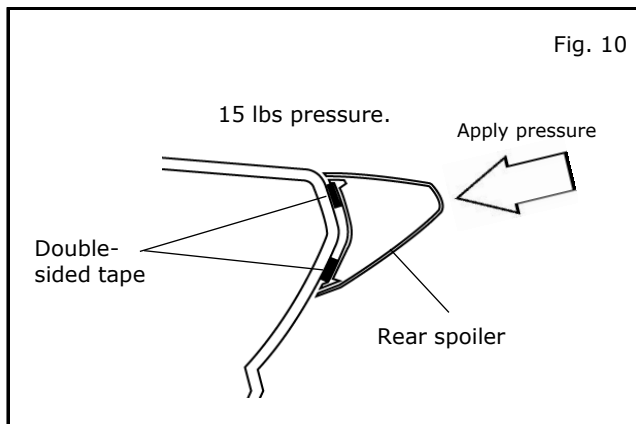
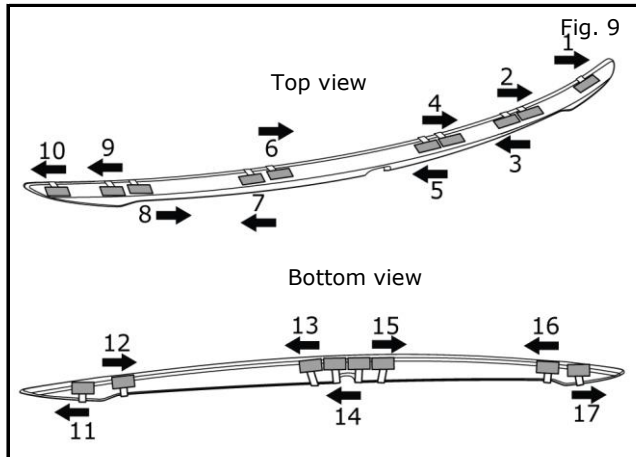
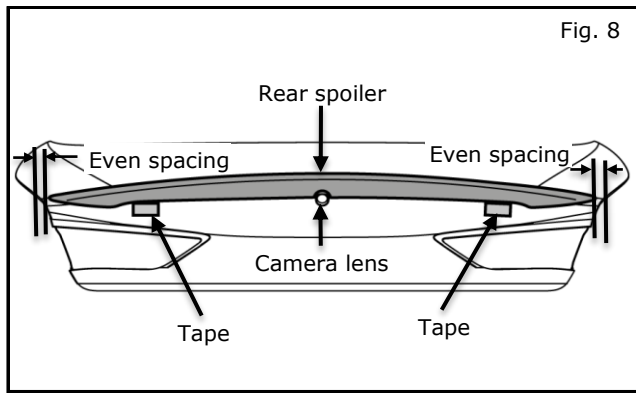

h) Before contacting tape to trunk lid, verify the spoiler is centered to the trunk lid and aligned to the position of the up/down masking tape indicator (Fig. 8).

i) After ensuring the spoiler is positioned correctly inboard/outboard and up/down, press spoiler to trunk lid.

j) Remove tape liners in numerical order and direction as shown in Fig. 9.

NOTE:

- **Ensure spoiler is properly aligned prior to removing tape liners and pressing spoiler in place.**
- **If tape liners are difficult to remove, slightly pull the spoiler away from the trunk lid to assist.**

k) Using micro fiber cloth, apply 15 lbs of pressure to the spoiler ensuring adhesive tape contacts the trunk lid all around. Apply pressure starting from center and move outboard. Pressure must be applied in direction shown by arrow.

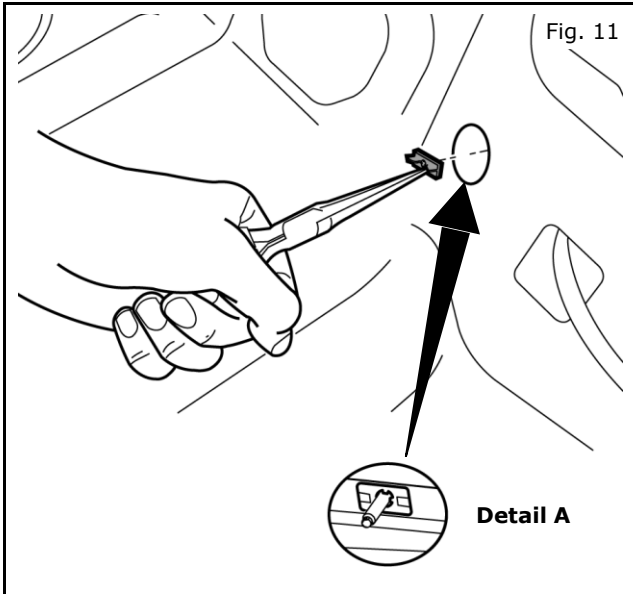

- 7) Install spacers and M5 nuts to studs.
- a) Open trunk lid
 - b) Using needle nose pliers, grip tab on spacer and insert over stud in 4 places.

NOTE:

Spacer is self retaining. See "Detail A."

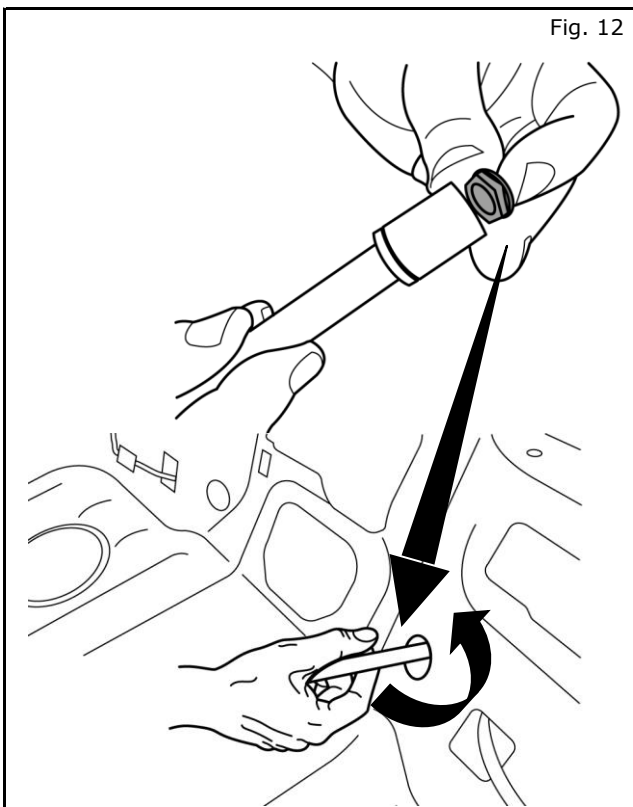

- c) Using socket, install M5 nuts to studs and tighten to 1.5 Nm torque.
- d) Remove tape alignment markers.
- e) Remove tape holding connectors out of drill path and reconnect (2) electrical connectors previously disconnected in step 5 (fig 6).

Note:

Ensure 3 electrical connectors (previously disconnected in step 5.) are properly engaged prior to moving to step 8.

Fig. 13

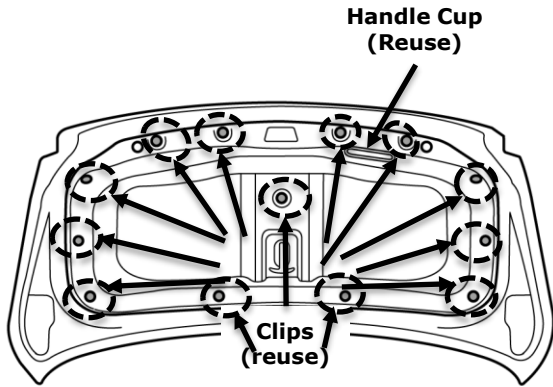

8) Reinstall :

- a) Inner Liner
- b) Pull Handle Cup
- c) Emergency Trunk Release
- d) Clips / Fasteners

Fig. 14

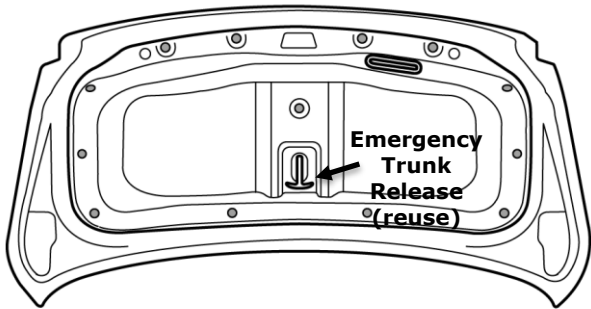

ACCESSORY CHECK:

- Please check that installation has no problem.

REINSTALLATION OF REMOVED PARTS

- Re-install all removed vehicle parts. Refer to the vehicle service manual for more details.
- Clean trunk opening of vehicle.

FINAL INSPECTION:

- Verify re-installed trim parts for proper flush fit
- Verify all clips are fully engaged and locked.
- Verify re-installed trim parts are free from cracks, scratches or stress marks.

VEHICLE CHECK

- Remove all tools from vehicle.
- Buff with a soft cloth if necessary